

SPL-2/75 Two-Way Splitter/Combiner

Product Warranty

LF Engineering Co. warrants that, at the time of shipment the products manufactured are free from defects in material and workmanship. LF Engineering obligation under this warranty is limited to replacement or repair of the product within 1 year from the date of shipment.

860-526-4759 • www.lfengineering.com

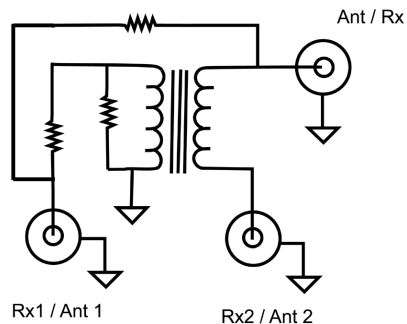

Copyright LF Engineering Co.
All rights reserved.
Printed in U.S.A.

LF Engineering Co.
17 Jeffery Road
East Haven, CT 06513

Model SPL-2/75 AM-BC Two-Way Splitter/Combiner

The **SPL-2/75 AM-BC Two-Way Splitter/Combiner** provides an impedance matched 75 ohm coaxial connection for two receivers when feeding signal from a single source. Typically used for distributed cabling systems requiring impedance matched taps for multiple receivers, or when combining two antennas for diversity reception.

The splitter consists of a low loss toroid matching network designed to maintain a low impedance signal split with high isolation between ports. Proper impedance matching is necessary for optimum performance especially when running feeder cable over long distances within a building.



Specifications - SPL-2/75

SPL-2 Size	2.4"L x 1.4"W x 0.75H"
Bandwidth	20 kHz to 30 MHz
Input Impedance	75 ohms
Output Impedance	75 ohms
Insertion Loss	< 1 dB above 6 dB splitter loss
Port Isolation	> 40 dB typical
Shorted Port Loss	< 1 dB
Maximum Power	500 mW
Connections	BNC

In splitter configuration, two receivers may be fed from one antenna. Shown below are four antenna configurations typically used with the SPL-2/75. Use coaxial extensions in lengths up to 100 feet using 75 ohm 1/4 inch coaxial cable.

The cumulative system loss is the total loss (in dB) of all feeder and extension cables, and the splitter loss for the SPL-2/75 itself.

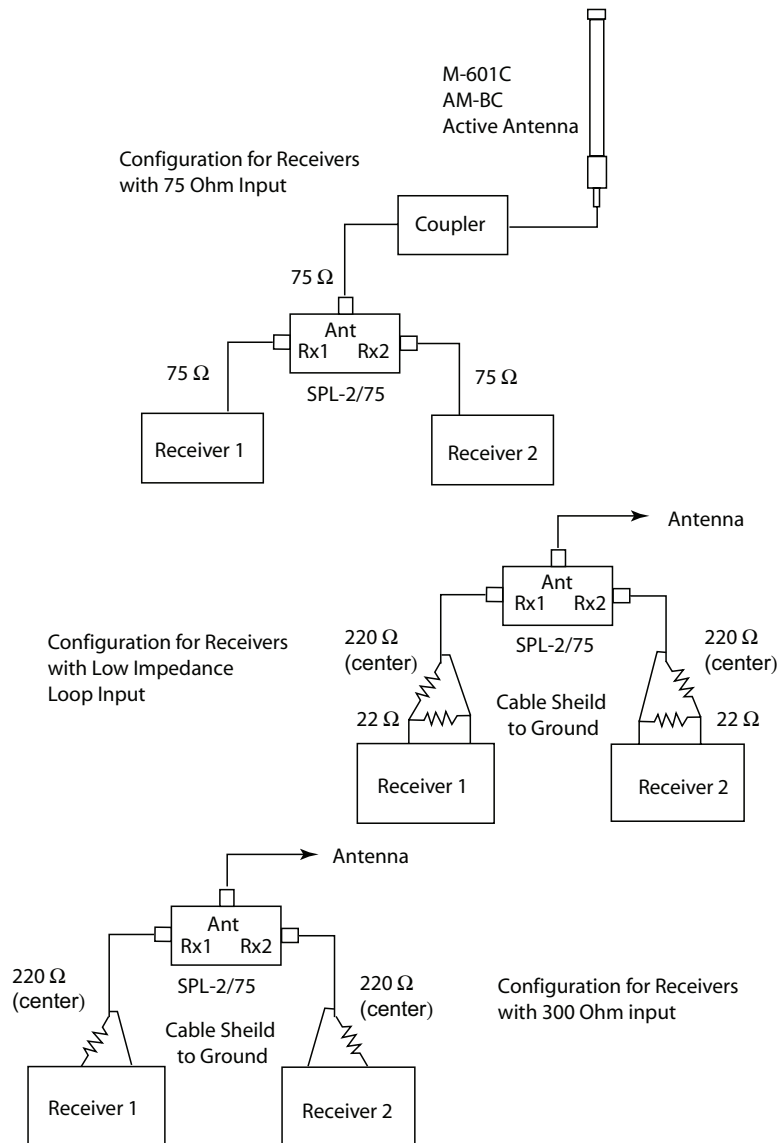

In combiner configuration, two different antennas may be used to feed one broadband receiver. Shown below are two suggested antenna configurations that may be used with the SPL-2/75.

The cumulative system loss is the total loss (in dB) of all feeder and extension cables, and the splitter loss for the SPL-2/75 itself.

