

Model M-607 AM BC Active Loop Antenna

The M-607 AM BC Active Loop Antenna is a broadband coaxial wound loop designed to be used in conjunction with an AM Broadcast receiver.

Frequency response is 530 kHz to 1720 kHz (broadband). The 24 inch square PVC loop may be broken down into components for storage. The loop antenna and receiver may be hand held or mast mounted.

The loop is constructed of multi-turn coax, and is secured to a light weight 24 inch diameter pvc collapsible frame. The antenna preamplifier is weather protected within a weatherproof housing and powered through the coaxial feed line. A 12 vdc power supply / coupler interface is provided with receiver connections.

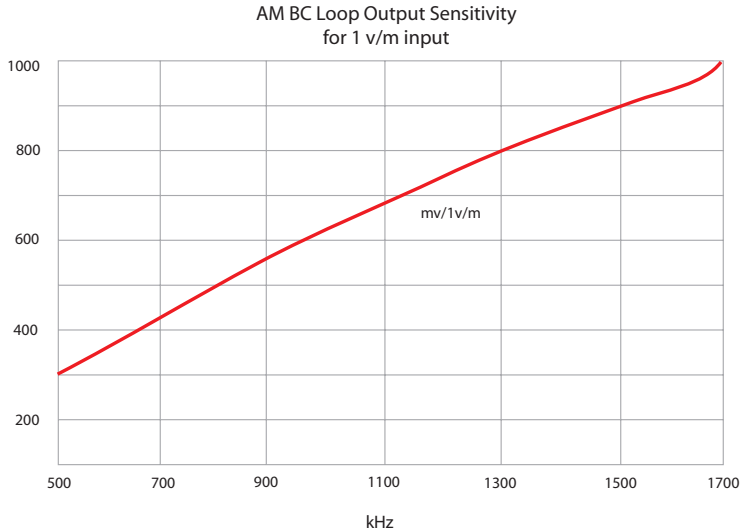
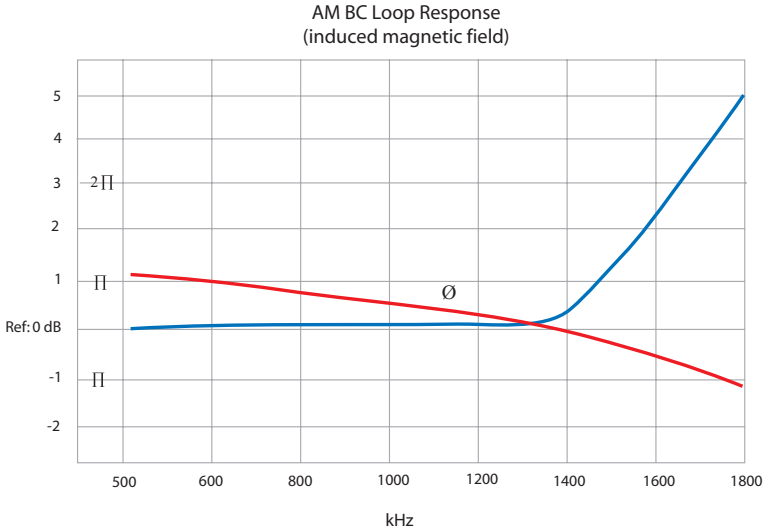

Specifications - M-607 AM BC Loop Antenna	
Frequency Response:	530 kHz to 1720 kHz +/-3dB (normalized loop response)
Sensitivity:	600mV/ V/m @ 1 MHz
Loop Amplifier Gain:	30 dB
IP3:	30 dBm
Loop Nulls:	>30 dB
Power Requirement:	12 - 15 Volts DC @ 40 mA
Connectors:	BNC
Size / weight:	24" square / 12" handle, 1.5 lb

WARRANTY

LF Engineering Co. Inc. warrants that at the time of shipment the M-607 AM BC antenna manufactured by LF Engineering Co. is free from defects in material and workmanship. LF Engineering Co. obligation under this warranty is limited to the replacement or repair of the product within 1 year from date of shipment.

The M-607 AM BC Active Loop Antenna is a balanced, broadband, peaked lowpass coaxial design providing exceptional sensitivity and directivity. The M-607 combines a 30dB high gain low noise amplifier with a balun input and with a heff of 5.9 mm loop input for 1 MHz, a sensitivity of 600 mV/V/m is achieved. Nulls of greater than 30 dB can be expected with the loop mounted in the clear.

Assembly - M-607 AM BC Active Loop Antenna

The Loop Antenna is in a partial kit form and must be assembled carefully to prevent damage to the wire loop - do not twist or kink.

Tools Required: medium size Phillips style screwdriver,
and a paper clip to be used as a guide pin.

Parts List:	Quantity	Description	Part Number
	1	Top Assembly	E6010
	2	Pipe Legs	L6020
	1	Main Loop Assy.	A6030
	1	Handle/Mount	H6040

1. Insert the two pipe legs into the main loop assembly and the top assembly to the legs. Note the guide markings on the two legs.
2. Use paper clip to align the elbow and leg holes. Assemble with the four side screws provided.
3. Remove the top corner clips and screws. Carefully mount the loop to the top corner clips and reattach to the corner elbows.
4. Assemble the handle/mount to the main frame and tighten.

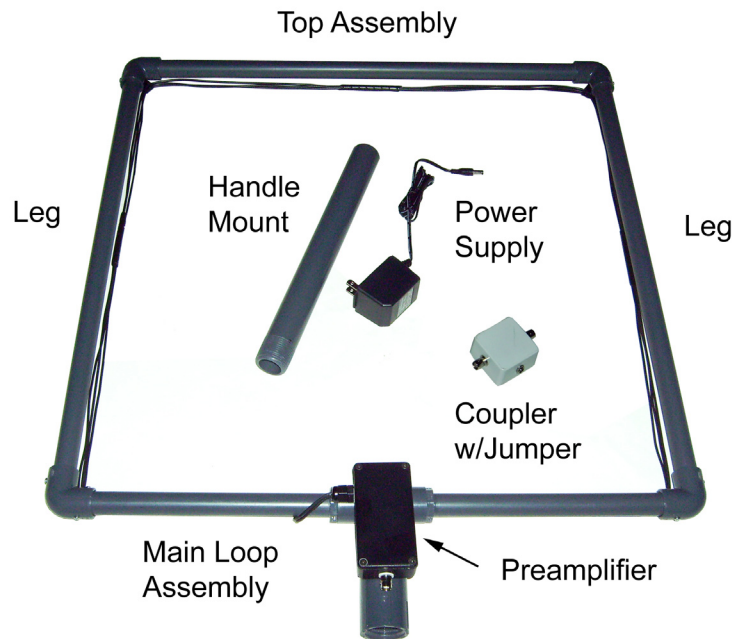

Connections - M-607 AM BC Active Loop Antenna

1. Connect a coaxial cable between the antenna preamplifier and the coupler interface box. Connect the supplied jumper between the coupler and your receiver.
2. Connect the 12 vdc power supply to the coupler to provide power to the antenna preamplifier.

Operation - M-607 AM BC Active Loop Antenna

Rotate the loop for the best nulling or peaking of signals that you desire to monitor. As little as 10 degrees of rotation can null or peak a signal. Use the M-607 antenna with a good AM Broadcast receiver for best results.

For permanent outdoor mounting on a pole, marine 1-14 mount, or rotor, we suggest that the BNC coaxial connection to the preamplifier be weather proofed with sealant (supplied), and that sufficient cable strain relief be provided. For rotor mounting we recommend a rubber surround be used between the PVC mount and the rotor mast clamp.

Directional Finding Application - M-607 AM BC Active Loop Antenna

A unidirectional scheme using the M-607 Loop, SPL-2 Combiner and the M-601C E-probe works well in the AM region from 500 kHz to over 1700 kHz for direction finding applications.

1. On a known location signal, peak the signal on the loop with the potentiometer set in minimum position; observe S-meter level.
2. Null the signal with the loop, adjust the potentiometer for the same level observed on the S-meter.
3. Mark reference loop for either peak or null.
4. Readjust null in null position.

