

L-111 LF Converter & Active Antenna System

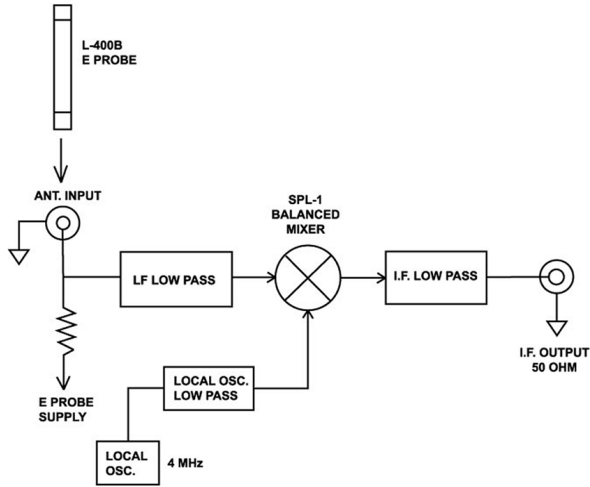

Product Warranty

LF Engineering Co. warrants that, at the time of shipment the products manufactured by LF Engineering Co. are free from defects in material and workmanship. LF Engineering Co. obligation under this warranty is limited to replacement or repair of such products within 1 year from the date of shipment.

For sales or return authorization, contact LF Engineering Co. at (860) 526-4759. For technical support call (203) 467-3590.

Copyright LF Engineering Co.
All rights reserved.

Printed in U.S.A.

LF Engineering Co.
17 Jeffry Road
East Haven, CT 06513

L-111 LF Converter & Active Antenna System

The L-111 Receiving System is the most sensitive LF Converter / Antenna System available for LF reception. The L-111 Receiving System provides full coverage of less than 3 kHz to 530 kHz, all within a compact and portable package..

The L-111 combines the L-400B active antenna with a LF to HF converter containing a low impedance, wide dynamic range balance mixer, with RF, IF and local oscillator filtering. The converters high L.O. rejection greatly improves reception below 10 kHz and its sharp filter roll off filter characteristics eliminate BC intermod. The L-111 Receiving System, plus a portable HF receiver is the perfect combination for VLF/LF listening in the field.



Features

- 3kHz to 530 kHz broadband coverage (no tuner required)
- High local oscillator rejection for vastly improved reception below 10 kHz
- No BC intermod can be detected even 1/4 mile from a 5 kW broadcast station operating on 960 kHz
- IF/RF isolation to prevent ground noise loops (jumper switchable)
- Extended ESD and RF protection
- Dual source power design: Internal 9 volt battery (x2) or external 120 vac / 12 vdc supply

L-111 Specifications

Antenna Probe Size	26 inches long, 1 inch dia.
Converter/Coupler Size	4.19"L x 2.74"W x 1.57"H
IF Output Frequency	4 to 4.5 MHz
System Frequency Response	3 kHz to 530 kHz \pm 5 dB
IF Rejection	80 dB typical
E Field Sensitivity	-3 dB @ 250 kHz (L-400B E-probe)
Input/Output Jacks	RCA
Output Impedance	50 - 100 ohms
Operating Temperature	-25°F to +120°F
Weatherproofing	Antenna probe tested to 2 atmospheres (-66 ft)
DC Power:	12 - 18 Volt, 30 ma, NEDA (2) or equivalent battery
AC Power: (included)	120 vac / 12 vdc power pack with 2.5 mm plug

Introduction:

The L-111 Active Antenna covers the full low frequency spectrum from below 3 kHz through 530 kHz. A proprietary low pass filter is used to prevent AM broadcast inter-modulation and a proprietary low noise 20 dB gain amplifier (2 wire feed) insures ample gain throughout the spectrum. The converter IF is isolated from the input to prevent ground loop noise, but may be connected with a jumper if desired - see photo. The high L.O. rejection allows low end rejection below 10 kHz. The local oscillator can be "zeroed" in by connecting a frequency counter to pin (3, 10 or 11) to ground and adjusting the trimmer capacitor on the clad side of the PC board - see photo. The output impedance of the L-111 is 50 to 100 ohms. The Converter/Coupler requires two 9 volt batteries (18v) for operation. An external 120 vac / 12 vdc power supply is included for continuous operation.

Battery Installation:

Remove the 4 Philip head screws from the four corners of the front panel. Lift the panel/circuit board from the cabinet and install two 9 volt batteries onto the two battery clips. Reassemble panel into cabinet. The battery life with normal intermittent operation is approximately one year.

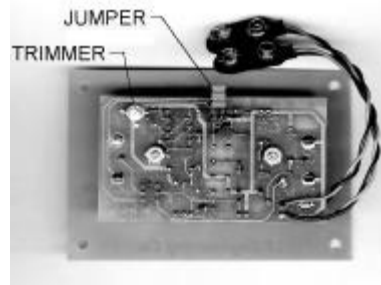

AC Power Supply:

The 120 vac / 12 vdc power supply plugs into the 2.5 mm jack located on the front panel. The ac power supply may be used even with a battery internally connected. The 2.5 mm plug disables the internal battery when inserted into the panel jack.

Installation:

1. Mount the antenna E probe in the clear 8 ft to 20 ft high in the clear, preferably roof height. Use the stainless clamp supplied for attachment to a vertical support pole.
 - a. A support pole may be any vertical structure made from wood, metal or PVC that is between 1 and 2 inches in diameter. You may use an external roof structure such as the top of a TV mast or roof vent pipe. Note: The use of a vent pipe or any other large diameter mounting surfaces will require a larger mounting clamp.
 - b. The support pipe should not be attached any higher than the neoprene grip as shown in the illustration.

2. Connect the converter/coupler output (RCVR) to the antenna input terminals of your shortwave receiver with input impedance between 50 & 100 ohms.
3. Route the antenna cable to your receiver. Longer lengths of cable may be added. Connect the antenna cable to the coupler (ANT) input.
 - a. Coax length may be extended 150 ft for a total of 200 ft max. length.
4. Turn the converter on and your receiver on. The coupler LED will light and your system is now ready for use.
5. Operating: When receiving, tuning is from 4 MHz to 4.5 MHz for reception of 0 to 500 kHz. Example; for receiving 100 kHz, 4.1 MHz is where you tune. This is true for either analog or digital readout receivers.

How to Get the Most Out Of Your L-111 Receiving System:

1. Keep your antenna in the clear and above metal objects (8 ft minimum height) and use a good ground on your receiver.
2. When mounting to a metal pole, mounting area should not exceed the neoprene grip.
3. Use a cable strain relief (clamp, strap, tape) around the mounting pipe and cable to reduce cable fatigue at the antenna.
4. Mount your antenna away from man made EMI such TV sets, light dimmers and other noise generators.
5. If using the L-111 converter with a long wire antenna (without E-probe), a tuner/impedance matching scheme between the long wire and the converter input must be used. Direct long wire hookup to the converter will result in overload and BC intermod throughout the operating band.

The simple coupler/impedance matcher shown below will work well throughout the spectrum when using 100 to 300 foot long wires. The LFE L-202B preamplifier will also work as a broadband impedance matcher.

